

10135307 - 10X LF

LEAD-FREE DESIGNATION ONLY WITH APPLICABLE PLATING CODES

SEE NOTE 2

MODULE DESCRIPTION

LETTER DESIGNATION REPRESENTED IN DASH NUMBER

BASE MODULE

LEFT POLARIZING GUIDANCE MODULE (SEE SHEET 3)

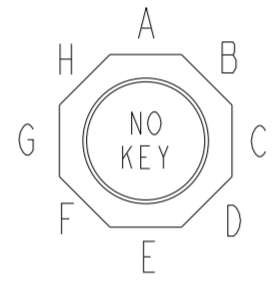
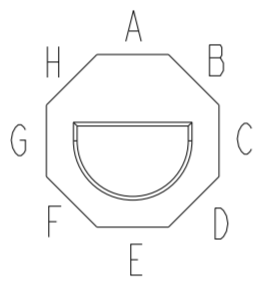
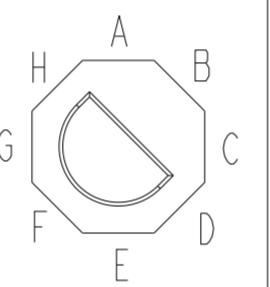
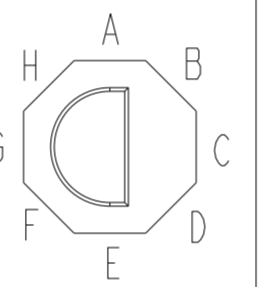
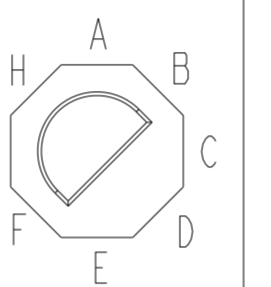
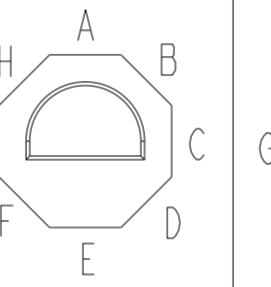
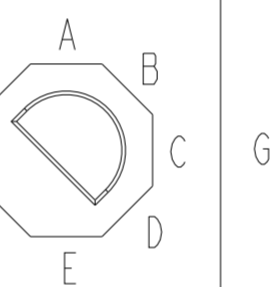
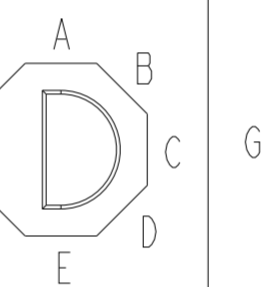
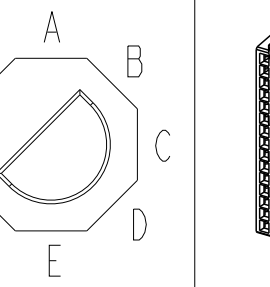
N	J (NO KEY)	A	B	C	D	E	F	G	H
NO KEY NO GUIDE PIN									

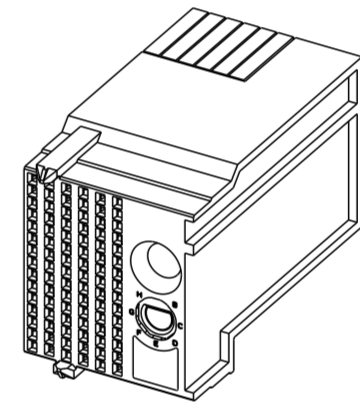

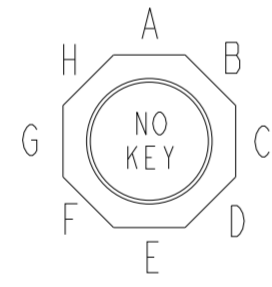
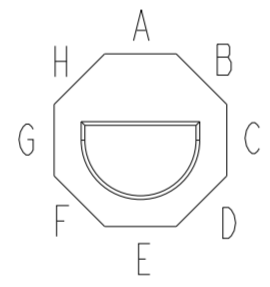
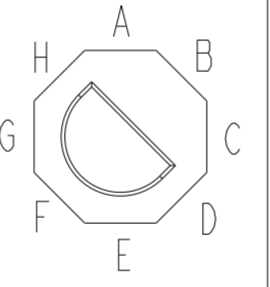
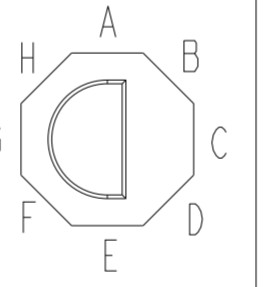
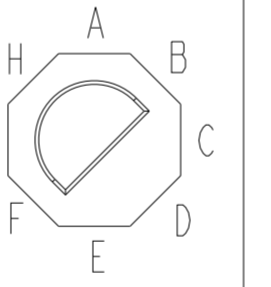
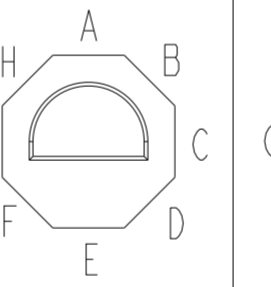
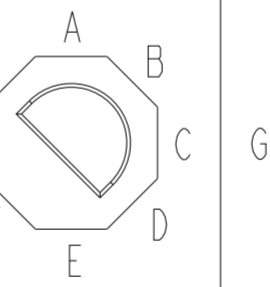
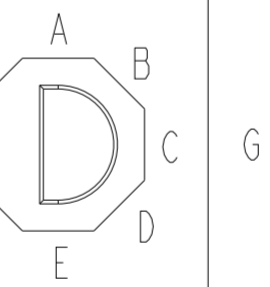
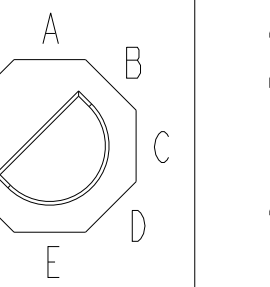

RIGHT POLARIZING GUIDANCE MODULE (SEE SHEET 2)

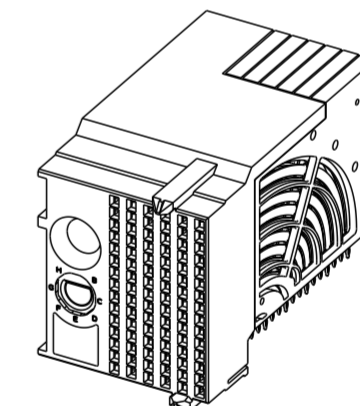
Z	Y (NO KEY)	P	Q	R	S	T	U	V	W
NO KEY NO GUIDE PIN									

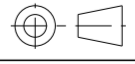
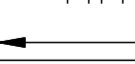

NO TOOLED
PRELIMINARY

spec ref	---	dr	Jackie Chen	2015/05/16	projection	MM	size	A2	scale	8:1	
tolerance std	ASME Y14.5M	eng	Jackie Chen	2016/03/15			ecn no	-	rel level	Preliminary	
TOLERANCES UNLESS OTHERWISE SPECIFIED		chr	-	product family							AirMax VS2
surface	- ✓	linear	0.X	±.3		title AIRMAX VS2 R.A. RECEPTACLE ASS'Y, 5 PAIR, 90 POS, 6 IMLA, 20MM, W/GUIDE/KEY	dwg no 10135307	rev 1	cat. no. -	Product - Customer Drw	sheet 1 of 4
			0.XX	±.15							
			0.XXX	±.050							
		angular	0°	±°							

Amphenol FCI

© 2016 AFCI

RIGHT POLARIZATION WITH GUIDE

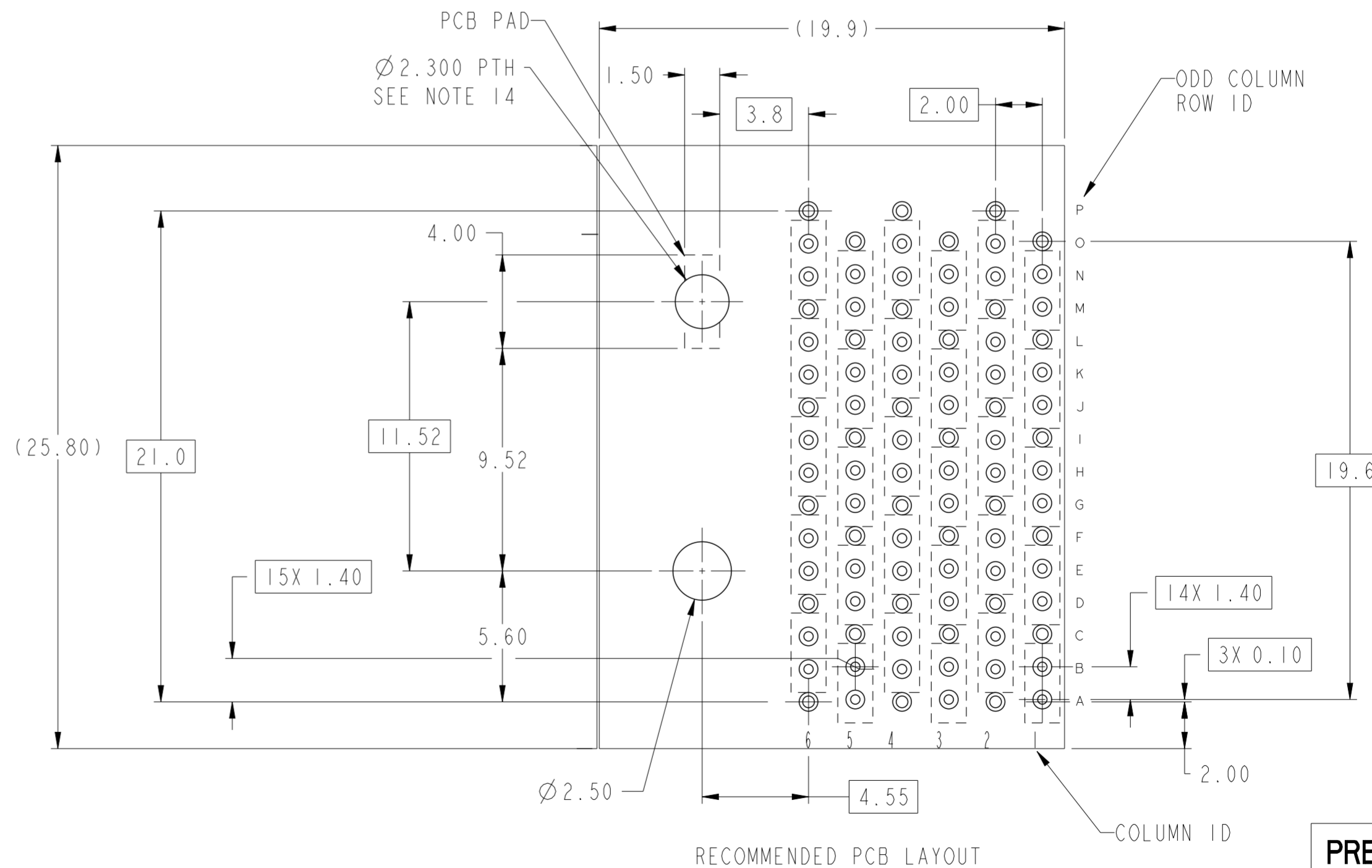
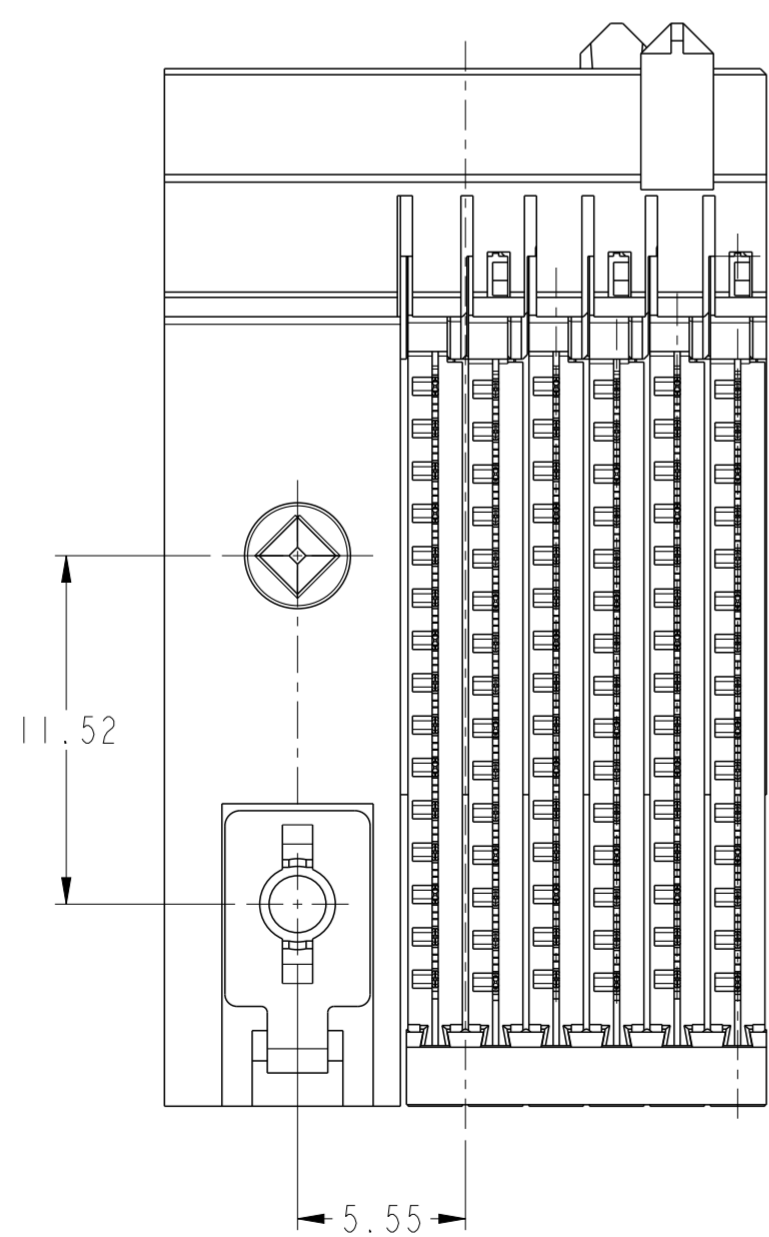
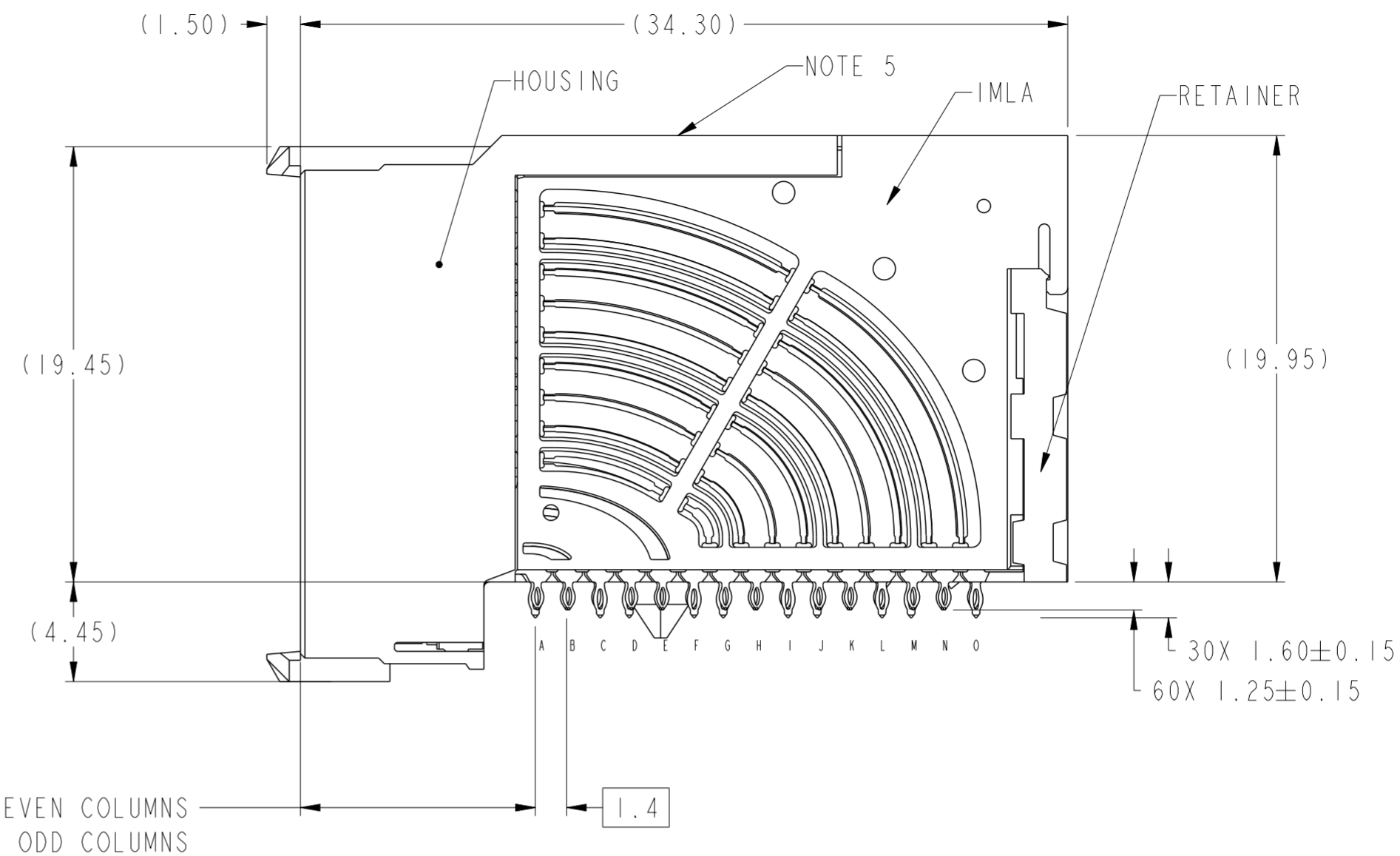
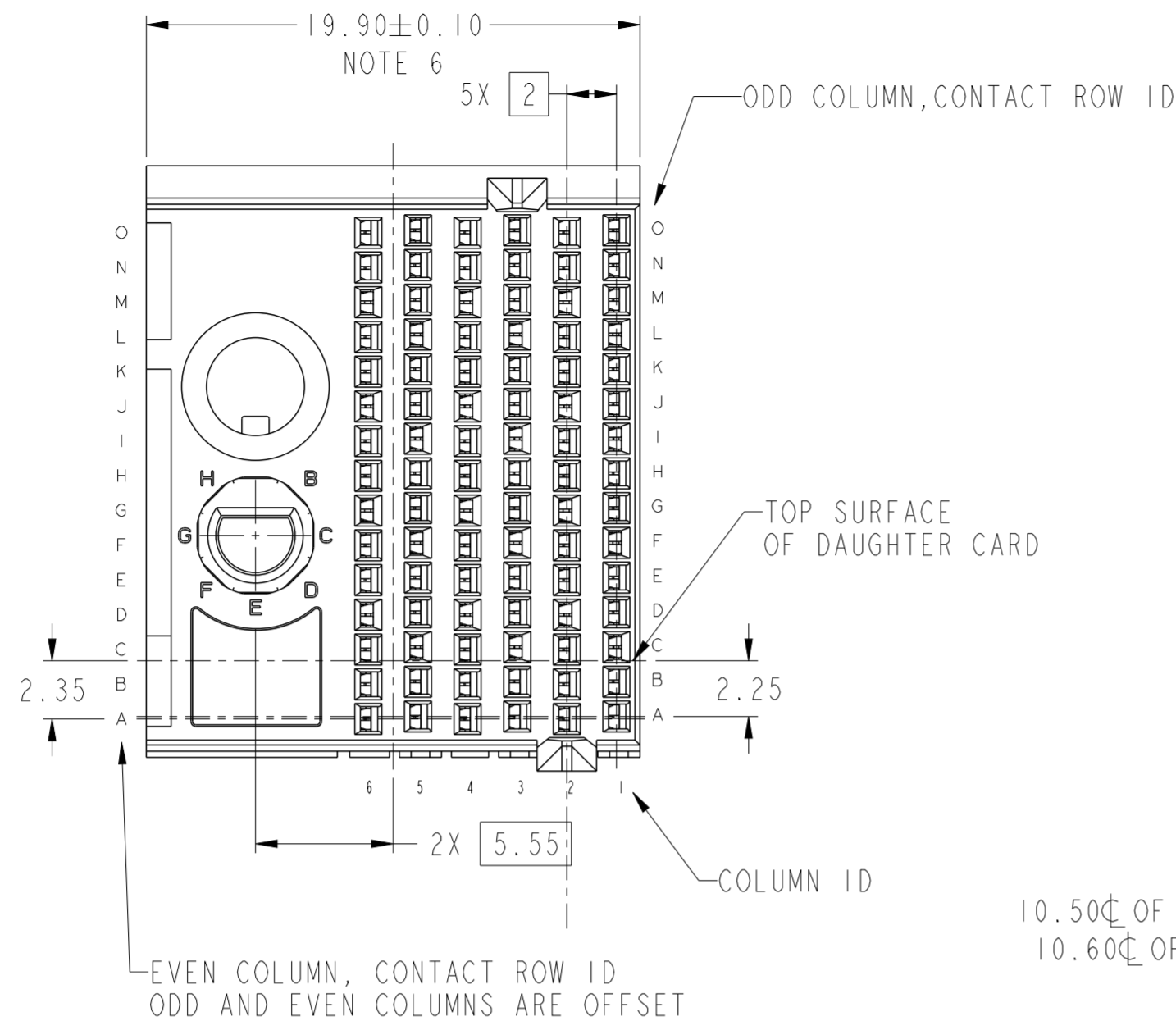

RECOMMENDED PCB LAYOUT

PRELIMINARY

spec ref	---	dr	Jackie Chen	2015/05/16	projection	MM	size	A2	scale	4:1
tolerance std	ASME Y14.5M	eng	Jackie Chen	2016/03/15	chr	-	ecn no	-	rel level	Preliminary
TOLERANCES UNLESS OTHERWISE SPECIFIED		appr	-	-	product family	AirMax VS2	part no	10135307	rev	1
surface	linear	0.X	±.3	Amphenol FCI	title	AIRMAX VS2 R.A. RECEPTACLE ASS'Y, 5 PAIR, 90 POS, 6 IMLA, 20MM, W/GUIDE/KEY	cat. no.	Product - Customer Drw	sheet 2 of 4	
		0.XX	±.15							
		0.XXX	±.050							
	angular	0°	±°							

Amphenol FCI

© 2016 AFCI

LEFT POLARIZATION WITH GUIDE

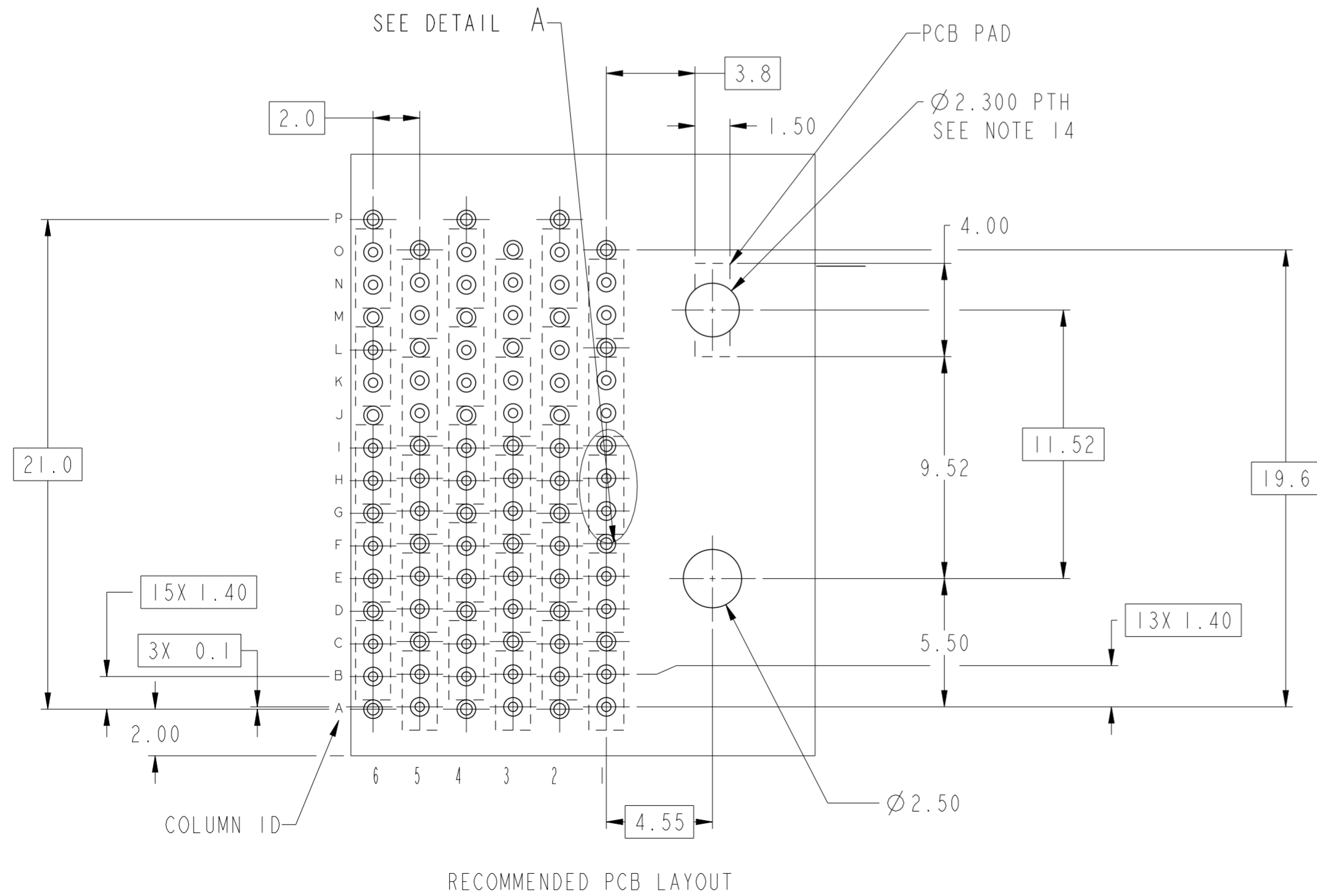
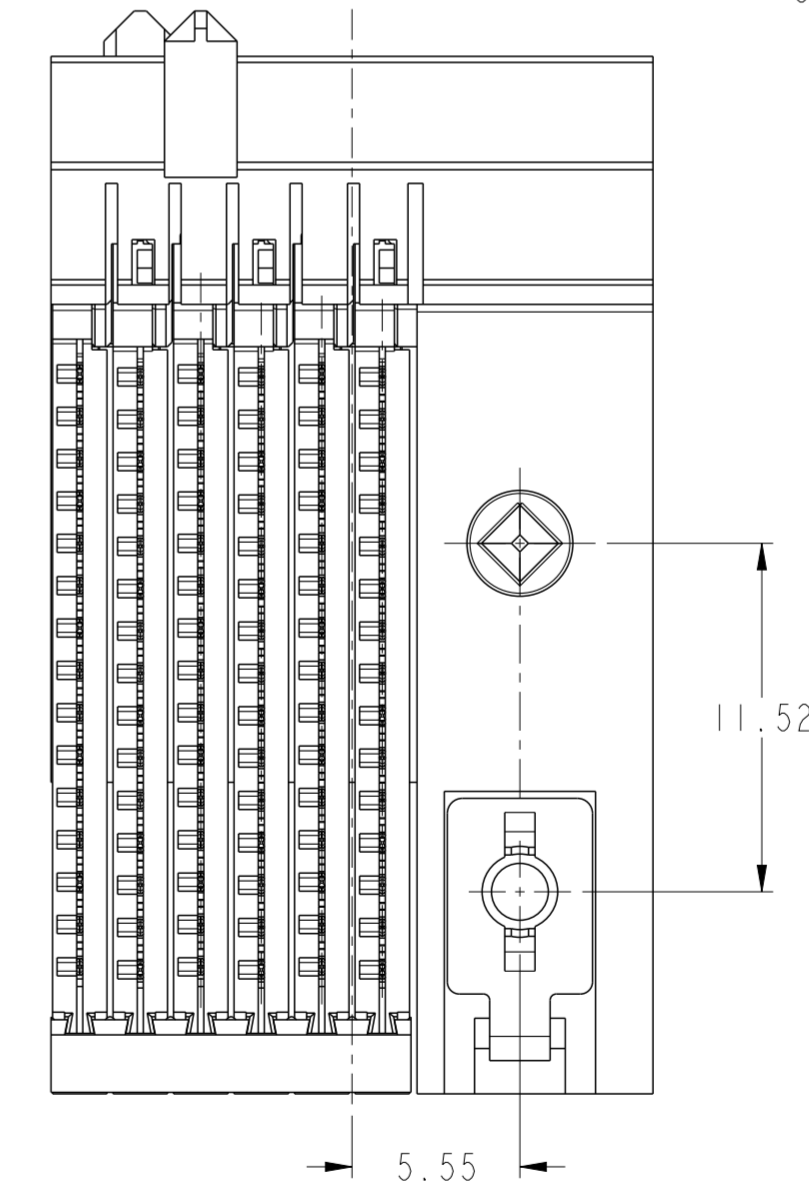
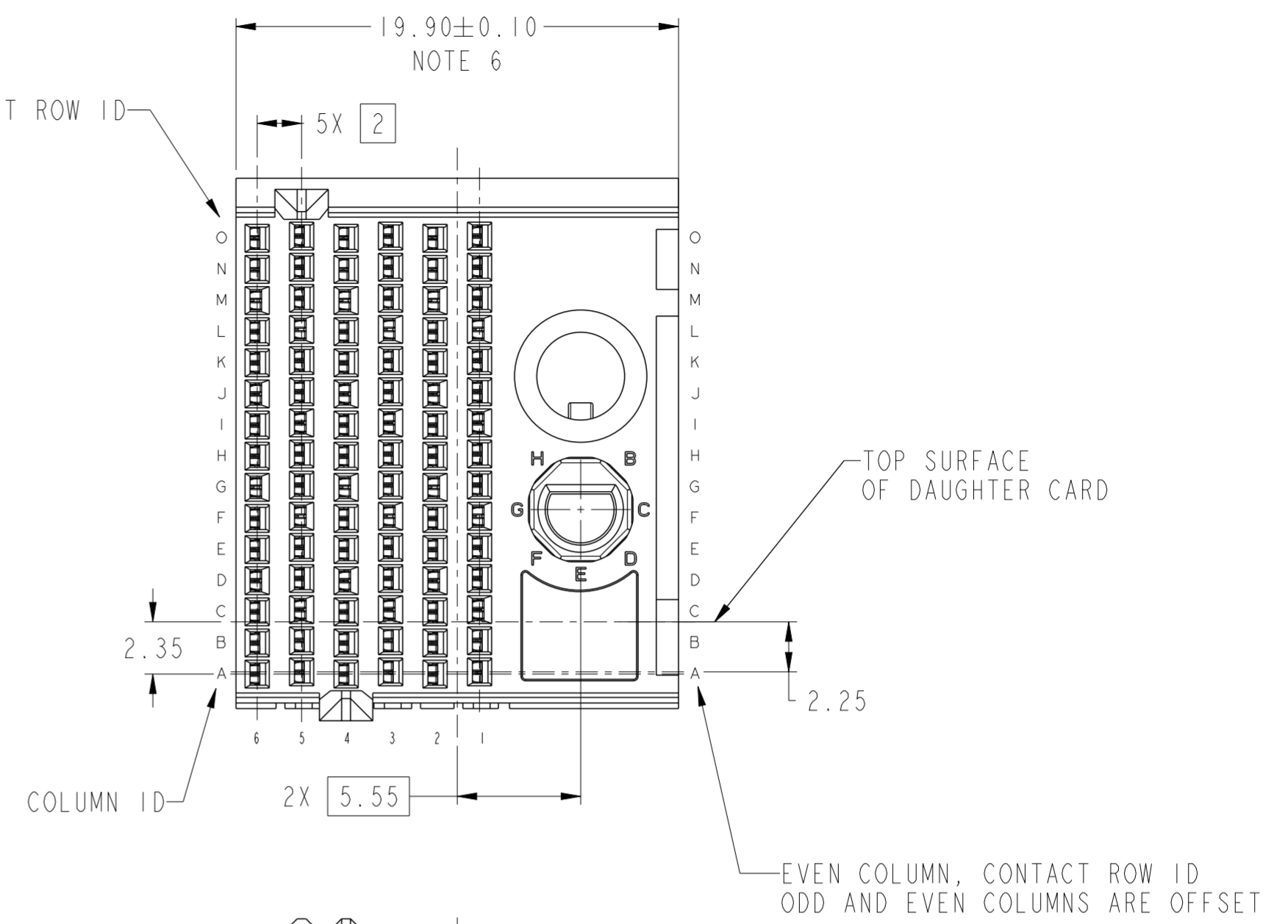
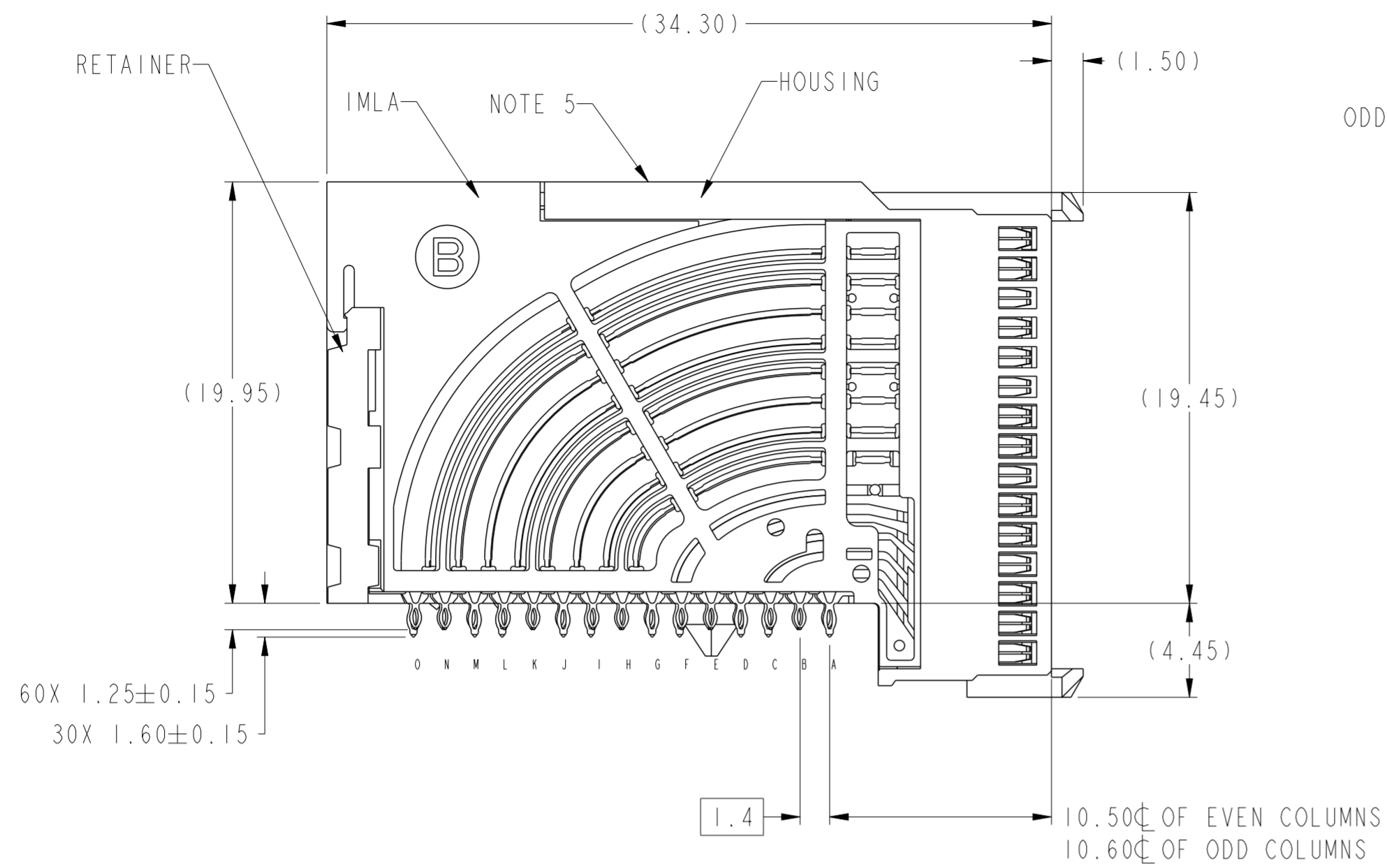

PRELIMINARY

spec ref	---	dr	Jackie Chen	2015/05/18	projection	MM	size	A2	scale	8:1
tolerance std	ASME Y14.5M	eng	Jackie Chen	2016/03/15			ecn no	-	rel level	Preliminary
TOLERANCES UNLESS OTHERWISE SPECIFIED		chr	-	app			-	product family		AIRMAX VS2
surface	-	linear	0.X	±.3		AIRMAX VS2 R.A. RECEPTACLE ASS'Y, 5 PAIR, 90 POS, 6 IMLA, 20MM, W/GUIDE/KEY	dwg no 10135307	rev 1	cat. no.	Product - Customer Drw
			0.XX	±.15						
			0.XXX	±.050						
		angular	0°	±°						sheet 3 of 4

PRODUCT NUMBER	PRESS-FIT TAIL PLATING TYPE
10135307-10ALF	TIN OVER NICKEL (LEAD FREE)
10135307-10PLF	TIN OVER NICKEL (LEAD FREE)

- 1 - CONNECTOR MATERIALS:
HOUSING: HIGH TEMP THERMOPLASTIC, NATURAL, UL94-V0
IMLA PLASTIC: HIGH TEMP THERMOPLASTIC, BLACK, UL94-V0
CONTACT: COPPER ALLOY
ORGANIZER: HIGH TEMP THERMOPLASTIC, WHITE, UL94-V0
- 2 - CONTACT PLATING:
SEPARABLE INTERFACE:
PERFORMANCE-BASED PLATING, QUALIFIED TO MEET THE REQUIREMENTS OF FCI PRODUCT SPECIFICATION GS-12-0956 INCLUDING TELCORDIA GR-1217-CORE (NOVEMBER 1995) CENTRAL OFFICE TEST SEQUENCE
- PRESS-FIT TAILS: SEE TABLE
- 3 - PRODUCT SPECIFICATION: GS-12-0956
- 4 - APPLICATION SPECIFICATION: GS-20-0305.
- 5 - PRODUCT MARKING, (PART NUMBER & LOT CODE), ON THIS SURFACE.
- 6 - THE MINIMUM CENTERLINE SPACING BETWEEN ADJACENT MODULES IS 20.0 MM.
- 7 - CONNECTOR OUTLINE MAY BE SCREEN PRINTED ONTO CUSTOMER PCB TO BE USED AS A GUIDE FOR MANUAL CONNECTOR PLACEMENT.
- 8 - REFER TO CUSTOMER DRAWING 10104444 FOR INFORMATION ON PCB HOLE DIAMETERS AND PLATING OPTIONS
- 9 - LEAD FREE PRODUCT MEETS THE EUROPEAN UNION DIRECTIVES & OTHER COUNTRY REGULATIONS AS DESCRIBED IN GS-22-008
- 10 - PACKAGING MEETS GS-14-920 LEAD FREE LABELING SPECIFICATION.
- 11 - GROUND CONTACTS (C, F, AND I IN ODD COLUMNS AND A, D, AND G, EVEN COLUMNS) REQUIRE (Ø0.500) FINISHED HOLES. SIGNAL LOCATIONS REQUIRE (Ø0.400) FINISHED HOLES.
- 12 - THESE OUTER VIAS (M) ARE OPTIONAL. WHILE NO CONNECTOR EONS ARE PRESSED INTO THESE HOLES WE RECCOMEND (Ø0.500) FINISHED HOLES AT THESE LOCATIONS TO PROVIDE GROUND SYMMETRY THROUGH THE PCB.
- 13 - A \triangle SYMBOL WILL BE NEXT TO ANY DIMENSION, VIEW, OR NOTE, WHICH HAS BEEN MODIFIED WITH THE CURRENT DRAWING REVISION
- 14 - CUSTOMER CAN FIX THE CONNECTOR WITH THREAD FORMING SCREW THROUGH THIS PTH. THE SCREW IS #2-32, THE VALID LENGTH OF SCREW IS 4.5MM PLUS THE THICKNESS OF PCB.

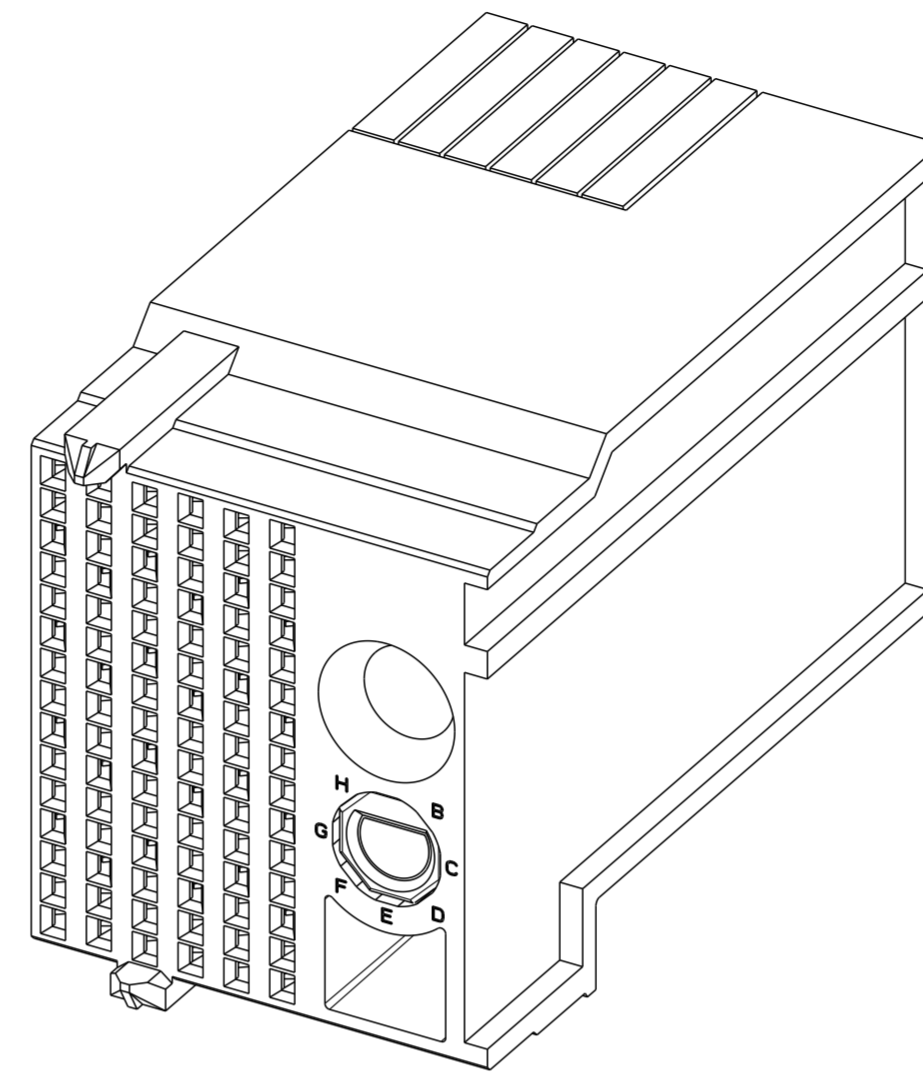

10135307-10ALF

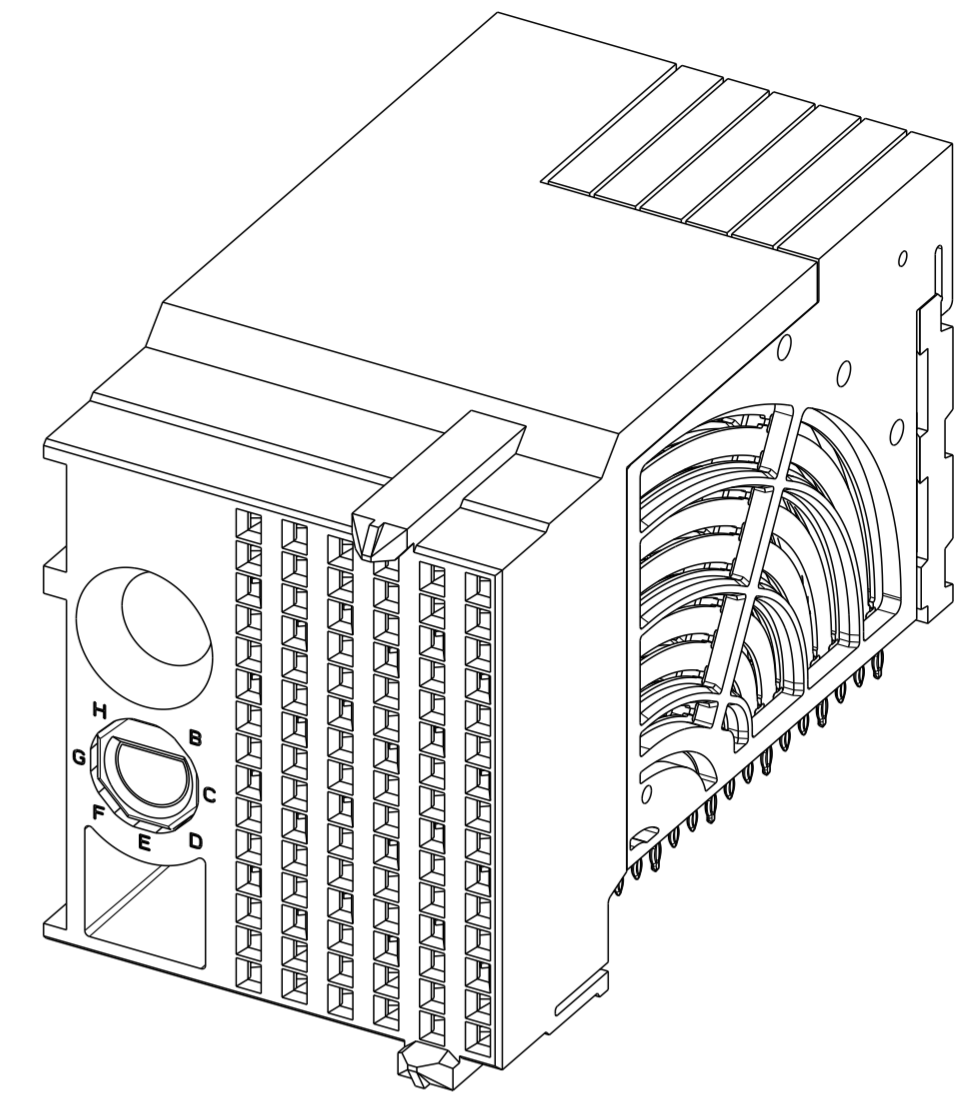

10135307-10PLF

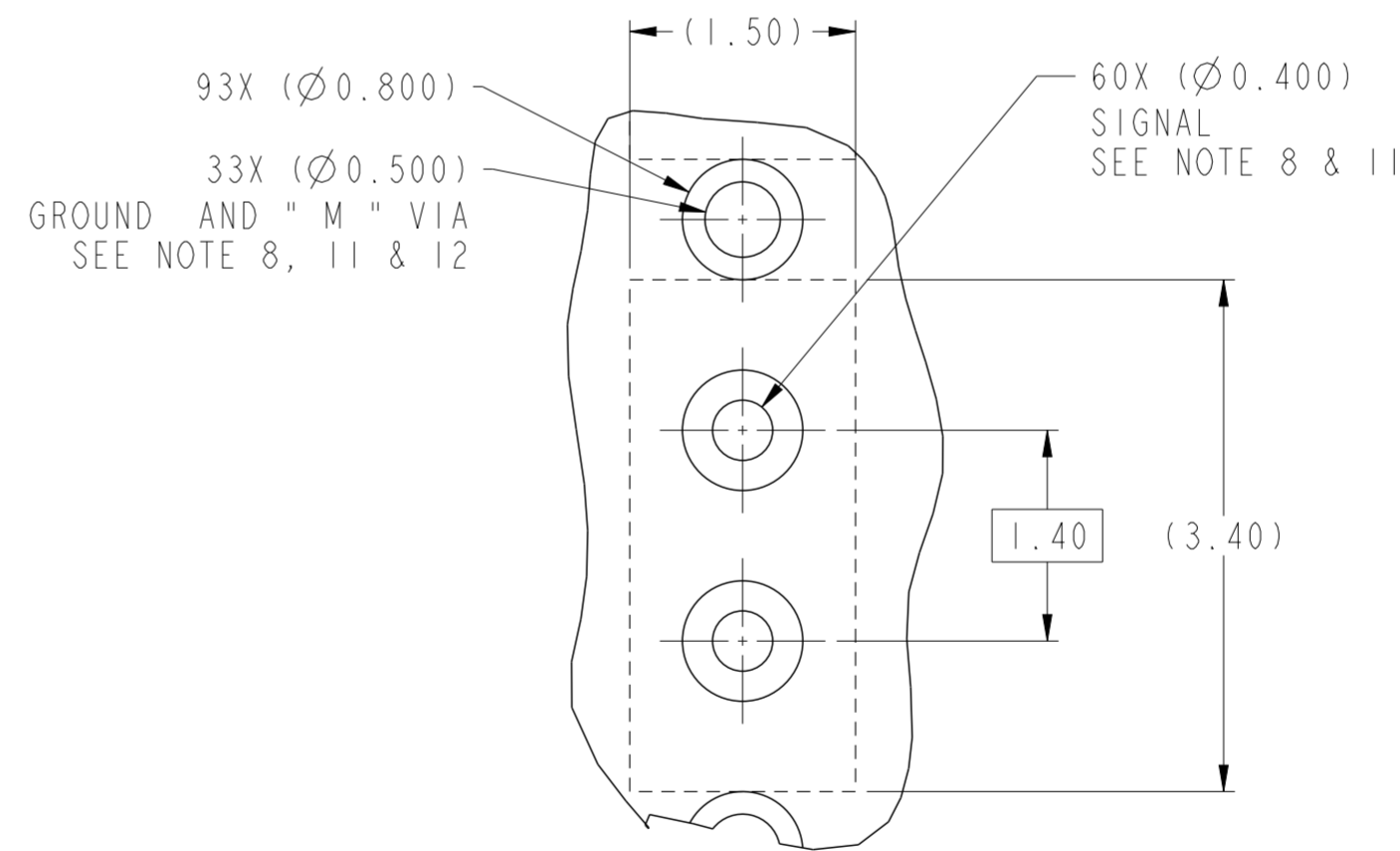

DETAIL A
SCALE 20:1

PRELIMINARY

spec ref	---	dr	Jackie Chen	2015/05/18	projection	MM	size	A2	scale	4:1											
tolerance std	ASME Y14.5M	eng	Jackie Chen	2016/03/15			ecn no	-	rel level	Preliminary											
TOLERANCES UNLESS OTHERWISE SPECIFIED		chr	-	appr			-	product family		AirMax VS2											
surface	<table border="1"> <tr> <td>linear</td> <td>0.X</td> <td>±.3</td> </tr> <tr> <td></td> <td>0.XX</td> <td>±.15</td> </tr> <tr> <td></td> <td>0.XXX</td> <td>±.050</td> </tr> <tr> <td>angular</td> <td>0°</td> <td>±°</td> </tr> </table>	linear	0.X	±.3		0.XX	±.15		0.XXX	±.050	angular	0°	±°			AIRMAX VS2 R.A. RECEPTACLE ASS'Y, 5 PAIR, 90 POS, 6 IMLA, 20MM, W/GUIDE/KEY		dwg no 10135307	rev 1	Product - Customer Drw sheet 4 of 4	
linear	0.X	±.3																			
	0.XX	±.15																			
	0.XXX	±.050																			
angular	0°	±°																			